

SS175 HELICAL PIERS AND ANCHORS 1/2" THICK HELIX

TORQUE STRENGTH RATING--11,000 FT-LB
 ULTIMATE CAPACITY*(COMPRESSION)--110 KIP
 * BASED ON A TORQUE FACTOR (K_t)=10
 SINGLE HELIX ULTIMATE STRENGTH--60 KIP
 ULTIMATE TENSION STRENGTH (COUPLING BOLT)--100 KIP

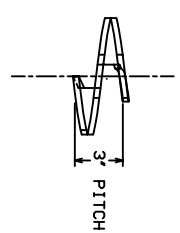
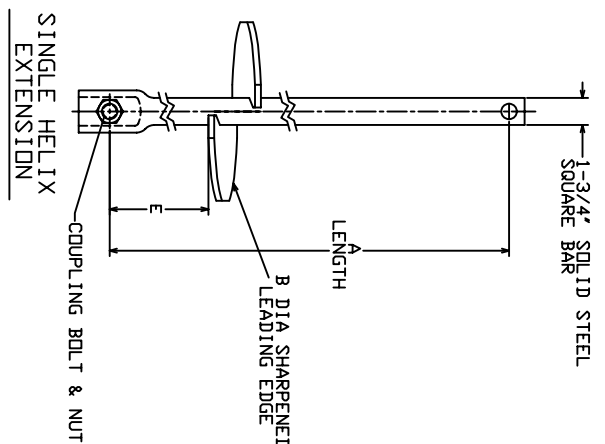
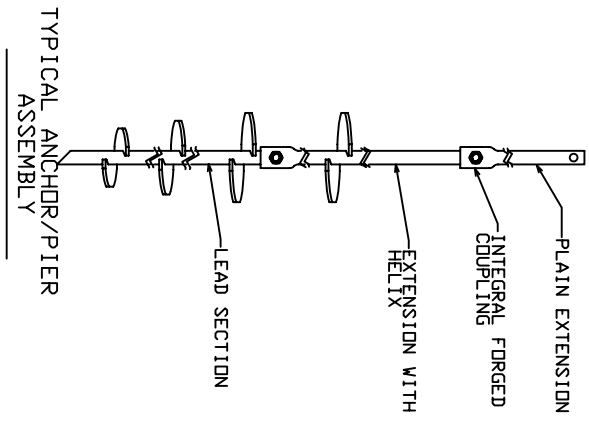
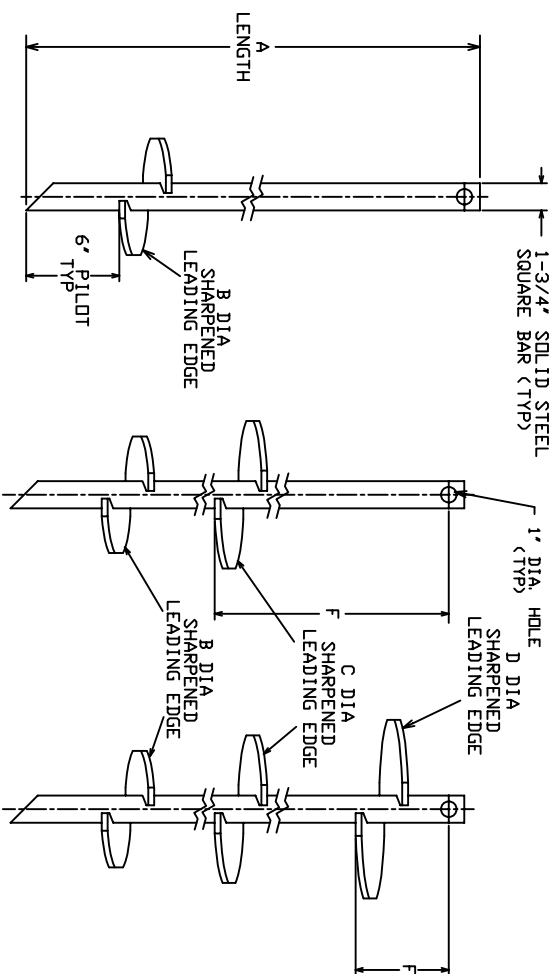

HELIX MUST BE FORMED BY MATCHING METAL DIE
 (SIDE VIEW OF TRUE HELICAL FORM)

==NOTES==

1. HOT DIP GALVANIZED PER ASTM A153-(LATEST REVISION).
2. LEAD AND EXTENSION SECTION LENGTHS AND HELIX SPACINGS ARE NOMINAL.
3. NOMINAL SPACING BETWEEN HELIX PLATES IS THREE TIMES THE DIAMETER OF THE LOWER HELIX.
4. SHAFT MATERIAL--HOT ROLLED ROUND-CORNERED-SQUARE (RCS) SOLID STEEL BARS PER ASTM A29; MINIMUM YIELD STRENGTH=90 KSI.
5. HELIX MATERIAL--HOT ROLLED LOW CARBON STEEL SHEET, STRIP, OR PLATE PER ASTM A656, OR A1018 GRADE 80; MINIMUM YIELD STRENGTH=80 KSI; 1/2" THICK.
6. COUPLING BOLTS: 7/8" DIAMETER X 3-1/2" LONG HEX HEAD PER ASTM A193 GRADE B7.
7. MANUFACTURER TO HAVE IN EFFECT INDUSTRY RECOGNIZED WRITTEN QUALITY CONTROL FOR ALL MATERIALS AND MANUFACTURING PROCESSES.
8. ALL WELDING TO BE DONE BY WELDERS CERTIFIED UNDER SECTION 5 OF THE AWS CODE D1.1.
9. REFER TO SA150-0183 FOR PLAIN EXTENSIONS AND TERMINATIONS.

		LEAD SECTION					
CAT. NO.		A	B	C	D	F	
T150-0264		64.5'	8'			58.5'	
T150-0263		64.5'	10'			58.5'	
T150-0262		64.5'	8'	10'		34.5'	
T150-0261		64.5'	8'	10'	12'	7.5'	
PSAT1500496		64.5'	6'			58.5'	

		HELICAL EXTENSION SECTION		
CAT. NO.		A	B	E
T150-0260		46'	14'	40'

CHANCE

HUBBELL POWER SYSTEMS

SS175 HELICAL ANCHORS
1/2" THICK HELIX

TITLE	SIZE	DWG. NO.	CMT. / PART / ASSY. NO.	REV.
SS175 HELICAL ANCHORS 1/2" THICK HELIX	SC1 SA150-0264	1/2"	SEE CHART	A

CONFIDENTIAL: THIS DRAWING AND ITS CONTENTS ARE CONFIDENTIAL AND THE PROPERTY OF HUBBELL POWER SYSTEMS. NO REPRODUCTION, DISTRIBUTION OR COPIES MAY BE MADE WITHOUT THE WRITTEN PERMISSION OF HUBBELL POWER SYSTEMS. UNPUBLISHED WORKS RESERVED UNDER THE PATENT LAWS.

DO NOT SCALE THIS DRAWING. DRN. BY KSH. DATE 4/12/06. SHEET 1/1