

==NOTES==

1. FINISH: HOT DIP GALVANIZE PER ASTM-A153 (LATEST REVISION).
2. BASEPLATE TO BE PERPENDICULAR TO SHAFT AXIS ($\pm 1^\circ$) AND HOLE CENTERLINE CONCENTRIC ($\pm .188$) TO SHAFT AXIS.
3. STENCIL MIN. 1/2 IN. LETTERS MANUFACTURER'S NUMBER AFTER GALVANIZING.
4. FLAME CUT TWO SLOTS IN SHAFT PERPENDICULAR TO THE BASEPLATE.
5. PREHEAT, TUMBLEBLAST, HANDGRIND, AND CLEAN BASEPLATE, HELIX, AND PILOT POINT ON ALL WELDED AREAS.
6. FLAMECUT IRREGULARITIES PERMISSIBLE: (1) VALLEYS NOT TO EXCEED 3/32 IN. BELOW NOMINAL SURFACE LEVEL, (2) PEAKS OR POSITIVE IRREGULARITIES NOT TO EXCEED 1/32 IN. ABOVE NOMINAL SURFACE LEVEL OR INTERSECTIONS OF NOMINAL SURFACES.
7. MANUFACTURER TO HAVE IN EFFECT INDUSTRY RECOGNIZED WRITTEN QUALITY CONTROL FOR ALL MATERIALS AND MANUFACTURING PROCESSES.
8. ALL MATERIAL IS TO BE NEW, UNUSED AND MILL TRACEABLE MEETING THE FOLLOWING SPECIFICATIONS:

BASEPLATE: ASTM A36-(LATEST REVISION) HOT ROLLED STEEL PLATE

SHAFT: STEEL TUBING, PER ASTM 500 GRADE B STRUCTURAL.

HELIX: ASTM A635-(LATEST REVISION) 3/8" THICK HOT ROLLED STEEL PLATE OR COIL.

9. BASEPLATE PERMANENTLY MARKED TO INDICATE CABLEWAY OPENINGS IN SHAFT.

T112-0393 HARDWARE PACKAGE INCLUDES:
 (4) .75"X3.5" SAE J429 GR.5 GALV. CARRIAGE BOLTS
 (4) ROUND FLAT WASHERS
 (4) .75" NUTS

MAT'L: HOT DIP GALVANIZED STEEL
 HARDWARE ORDERED SEPARATELY

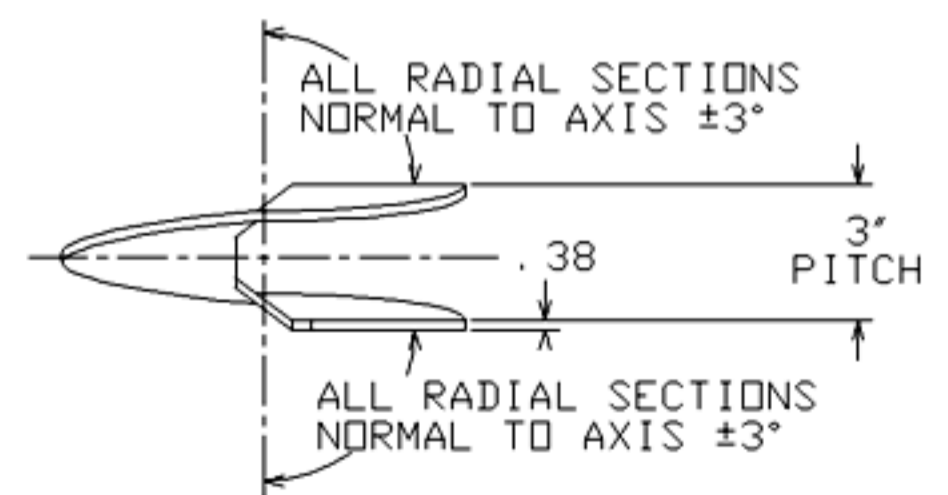
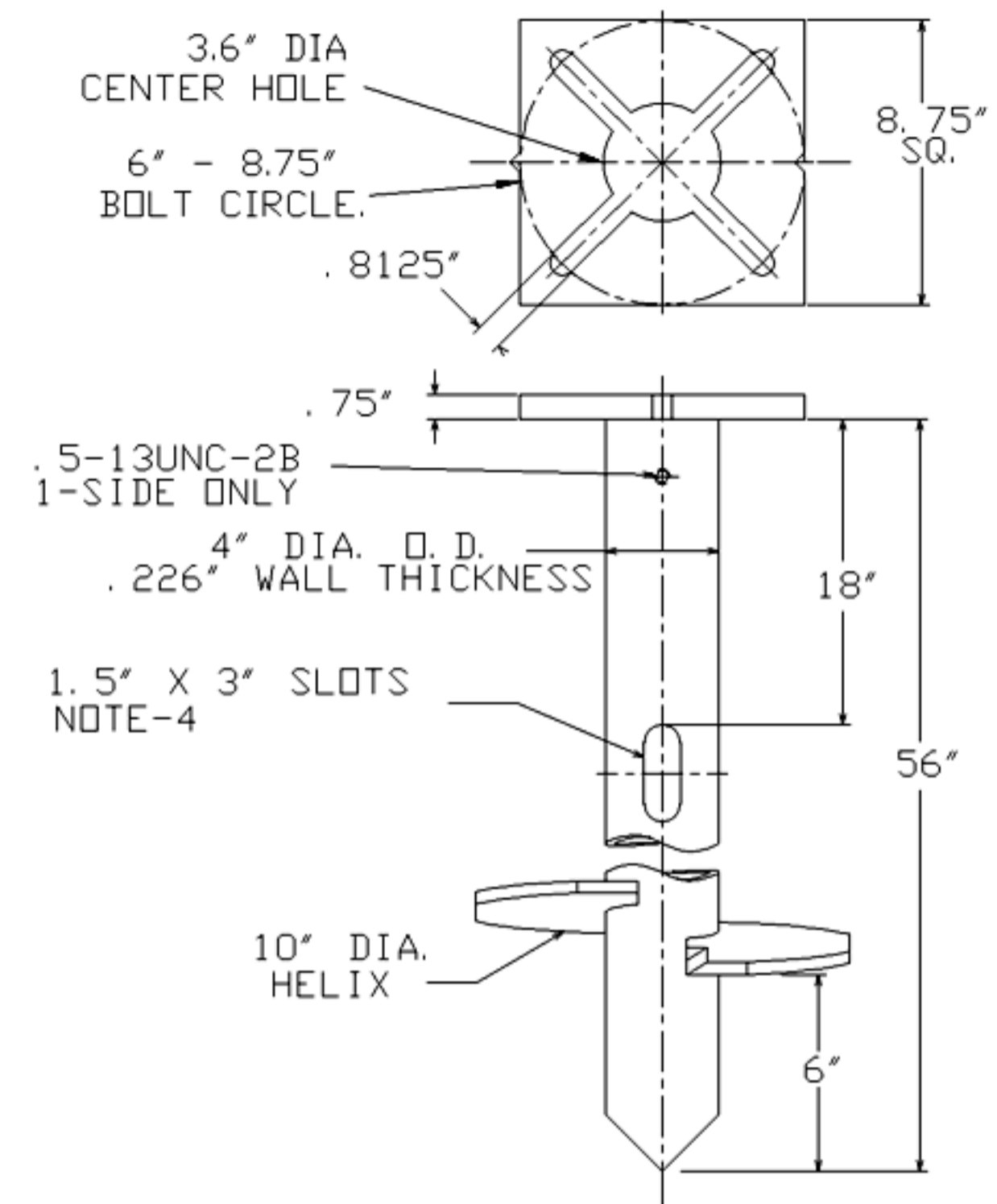

HELIX MUST BE FORMED BY MATCHING METAL DIE
 (SIDE VIEW OF TRUE HELICAL FORM)

DECORATIVE LIGHTING FOUNDATION
 CAT. NO. T112-0338
 MOUNTING HARDWARE ORDER T112-0393

CHANCE		 HUBBELL® POWER SYSTEMS <small>POWER SYSTEMS, INC.</small>	
CONFIDENTIAL: THIS DRAWING AND ITS CONTENTS ARE CONFIDENTIAL AND THE EXCLUSIVE PROPERTY OF HUBBELL POWER SYSTEMS. NO PUBLICATION, DISTRIBUTION OR COPIES MAY BE MADE WITHOUT THE WRITTEN CONSENT OF HUBBELL POWER SYSTEMS. HUBBELL POWER SYSTEMS UNPUBLISHED ALL RIGHTS RESERVED UNDER THE COPYRIGHT LAWS.			
TITLE		DECORATIVE LIGHTING FOUNDATION	
SIZE	DWG NO.	REV	
SB	SA112-0338	K	
DO NOT SCALE THIS DRAWING	DRN BY KSH	DATE 11/22/04	SHEET 1